

STAIRLADDER ASSEMBLY INSTRUCTIONS

- incorporating fall protection -

TOWER EN 1004:2004 CLASS 2 1.5kN per sq. m. U.D.L.
Classification: EN 1004 – 2 – 8/12 – B (B = Stairladder)

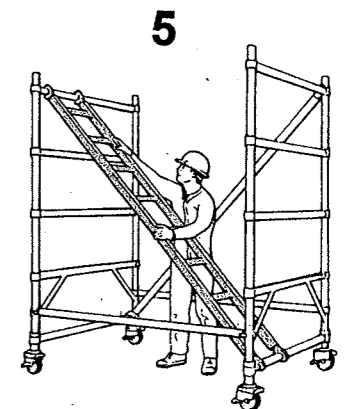
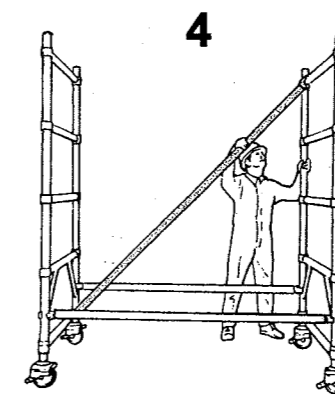
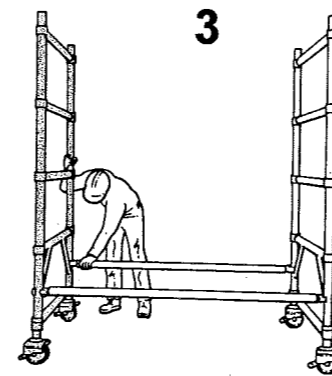
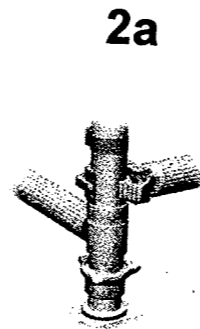
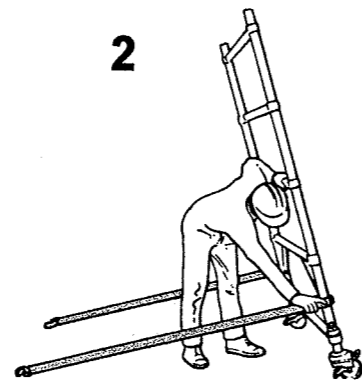
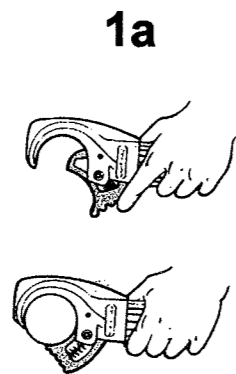
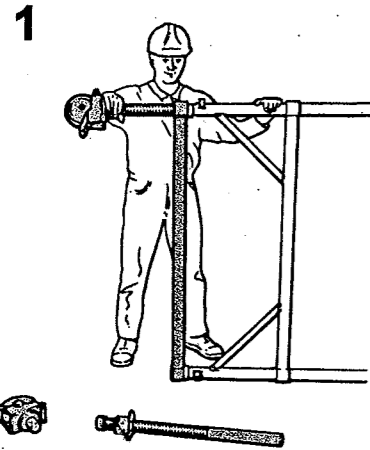

RECOMMENDATION: MINIMUM 2 PERSONS TO ERECT & DISMANTLE

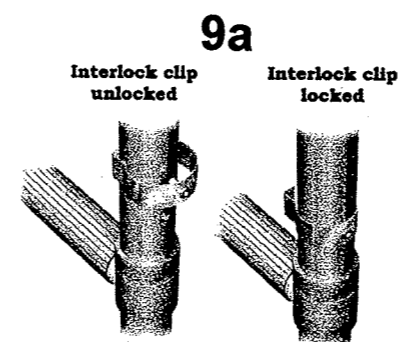
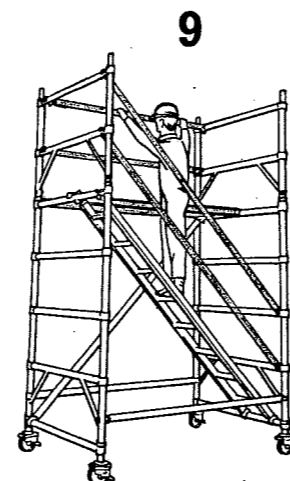
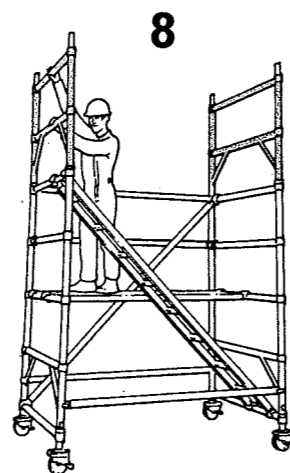
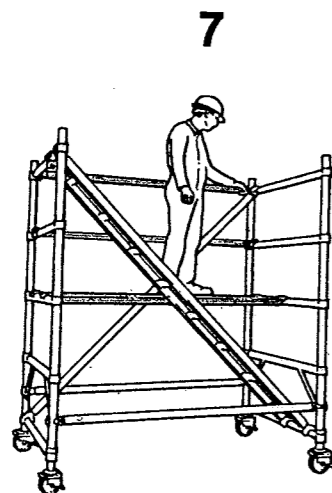
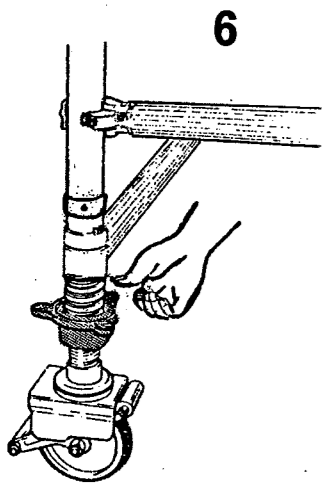

Lock frame using Interlock clip.

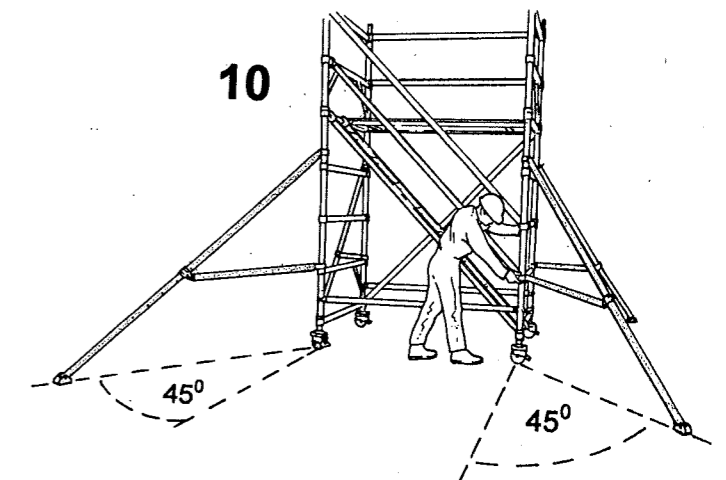

FOR 3/5/7/9/11 m

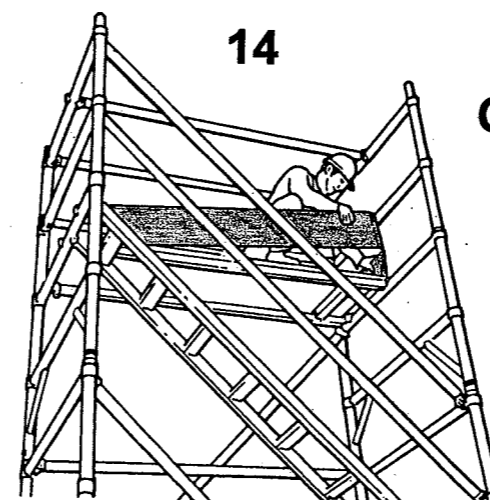
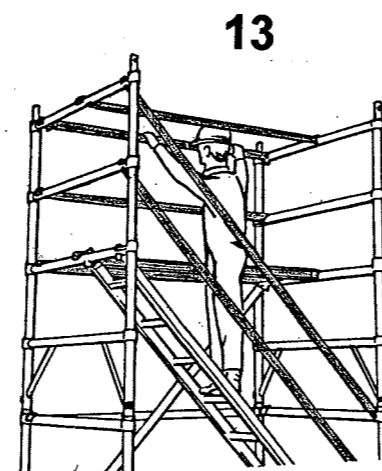
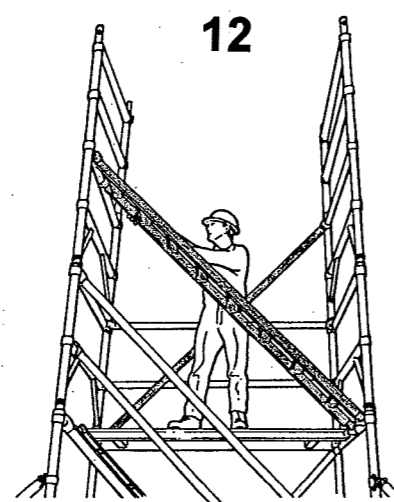
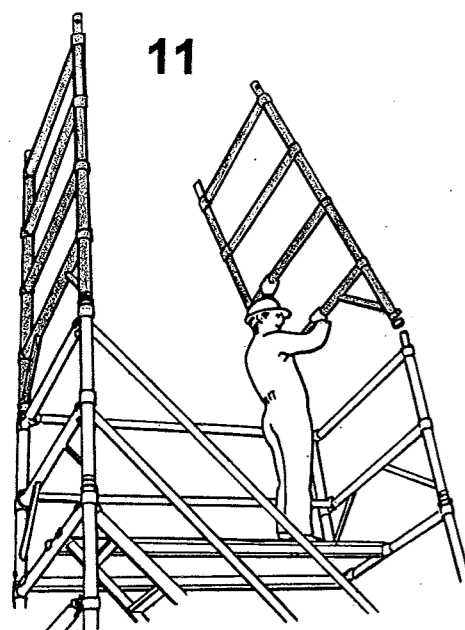

OR

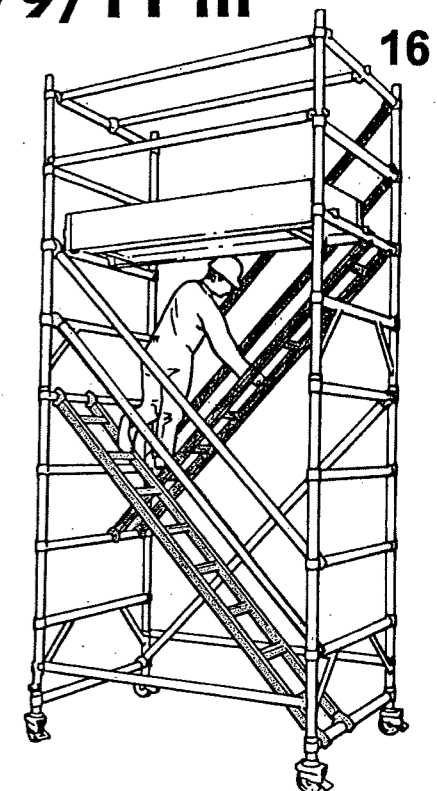
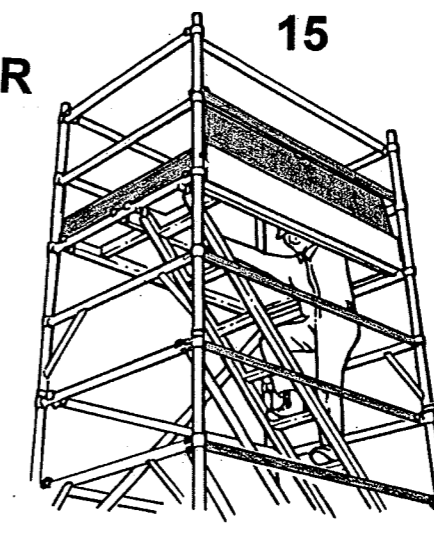

Reverse Assembly Procedure
for Dismantling Towers

BASIC SAFETY NOTES

1. Mobile access and working towers may only be erected and dismantled by persons familiar with these instructions, basic safety notes and maintenance rules. To reduce the risks of injury to any person the regulations require that operatives are trained, or are supervised by a person who has been trained.
2. All competent persons, or persons being supervised, must report any condition concerning their health and fitness, regarding diseases, physical and mental conditions which might pose a risk in undertaking work at height.
3. It is strongly recommended that the following items of personal protective equipment (PPE) be worn at all times: safety helmet; safety boots; gloves – to the appropriate EN or BS requirements. Note: additional PPE may also be required for some tasks, specific locations, premises and sites.
4. Damaged, incomplete, incompatible or improperly erected equipment must not be used.
5. Pass up tower components by handing up equipment (to persons positioned at different platform heights) or use a good rope ensuring it is securely tied to the components being hoisted.
6. Tower must be vertical and erected on level and firm ground. Ensure base plates/castors and stabilisers are in contact with the ground at all times. Lock castors.
7. Stabilisers must be fitted when required as shown on the tower components list in the assembly instructions. Never exceed the height to minimum base dimension for:- Inside use 3.5:1, Outside use 3.0:1 & 2.5:1 when moving the tower with stabilisers, to a maximum platform height of 4m.
8. Beware of strong wind conditions and whenever possible always "tie-in" the tower to a rigid structure. Do not erect or use a freestanding tower if wind speed is likely to exceed 7.7m/sec. 17mph or Beaufort force 4 (Moderate breeze: dust & paper blown about).
9. Never climb a tower from the outside. Always work from inside the tower on the platform board and within the guard railed area.
10. Do not lean ladders against the tower. Always use the ladders supplied with the tower. Never use ladders or boxes to gain additional height.
11. Never climb onto diagonals or handrails. Do not jump onto platforms or subject the tower to shock loads.
12. Ensure personnel, tools & materials are removed before moving or adjusting the tower. Do not attach bridging between a free standing mobile tower and a building.
13. When moving the tower push manually at the base only and do not exceed normal walking speed. Raise the stabilisers no more than 25mm (1") from the ground. After moving, re-lock castors, check for vertical alignment and ensure stabilisers are secure and have a sound footing. Re-tie to rigid structure.
14. Beware of overhead obstructions or electric power lines.
15. After erecting the tower conduct the Statutory Inspections: below 2m platform height (visual inspection); above 2m platform height (inspect & record on tag or inspection report form); other inspections (exceptional circumstances); and the 7 day inspection requirements.
16. If in doubt about the safe use of the tower, contact the supplier for advice.

MAINTENANCE RULES

1. Keep equipment clean and inspect before and after use for damage. e.g. Hooks/Castings/Welds – free from distortion and cracks; Tubes/Rungs/Braces – straight and no dents likely to affect structural integrity or performance; Platforms – no damage & free from debris; Castors/Adjustable legs – move freely, brakes work & threads not damaged; Frame locks/Toeboards – not damaged or missing; Stabiliser clamps – undamaged & operational. Use serviceable equipment only.
2. All working parts e.g. castors, legs, hooks and stabiliser clamps should be lubricated lightly with oil as necessary.
3. Repairs should only be carried out by the supplier or other competent person approved by the supplier.

SAFE WORKING LOADS - evenly distributed

272 kg (600lbs) each platform; 360 kg (800lbs) any platform level;
680 kg (1500lbs) load on base section; 150 kg (331lbs) each ladder/stairladder/stairway;
Castors:- From 225 kg (500lbs) to 820 kg (1800lbs) – see SWL stamped on each castor.

MAXIMUM PLATFORM HEIGHT OF TOWER WITH STABILISERS/OUTRIGGERS CORRECTLY FITTED (for guidance only – refer to the component breakdown which shows when stabilisers are required)

INTERNAL:- 3.5:1 minimum base dimension: EXTERNAL:- 3.0:1 minimum base dimension: MOVING A TOWER FITTED WITH STABILISERS:- 2.5:1 minimum base dimension, to a maximum platform height of 4m.

WARNING

INJURY OR DEATH MAY RESULT FROM FAILURE TO COMPLY WITH THE ASSEMBLY INSTRUCTIONS, BASIC SAFETY NOTES, MAINTENANCE RULES, SAFE WORKING LOADS AND MAXIMUM PLATFORM HEIGHT OF TOWER.

TOWER EN 1004:2004 CLASS 2 1.5kN per sq.m. U.D.L.

MAXIMUM HEIGHT 8M OUTDOORS 12M INDOORS

Classification: EN1004-2-8/12-ABCD (depending on tower design & access to platforms)

Access type:- A: Stairway – DW x 2.0m Span length towers

B: Stairladder – DW x 2.0m Span length towers

C: Inclined ladder – DW, SW & SW Plus (+) x 2.0/2.5/3.0m Span length towers

D: Vertical ladder – DW, SW & SW Plus (+) x 1.2/1.5/2.0/2.5/3.0m Span length towers

Ability International Limited: BS EN ISO 9001:2000 Registered Company. Certificate No. 4011767

NATIONAL BRITANNIA SAFEcontractor Accreditation. Certificate No. N00073832

Instruction Manual EN 1298 – IM - GB

This page updated July 2007

Ability

CONTRACT SERIES OF ALUMINIUM TOWERS

STAIRLADDER TOWER



**TOWER EN 1004:2004 CLASS 2
1.5kN per sq. m. U.D.L.**

**MAXIMUM HEIGHT
8M OUTDOORS
12M INDOORS**

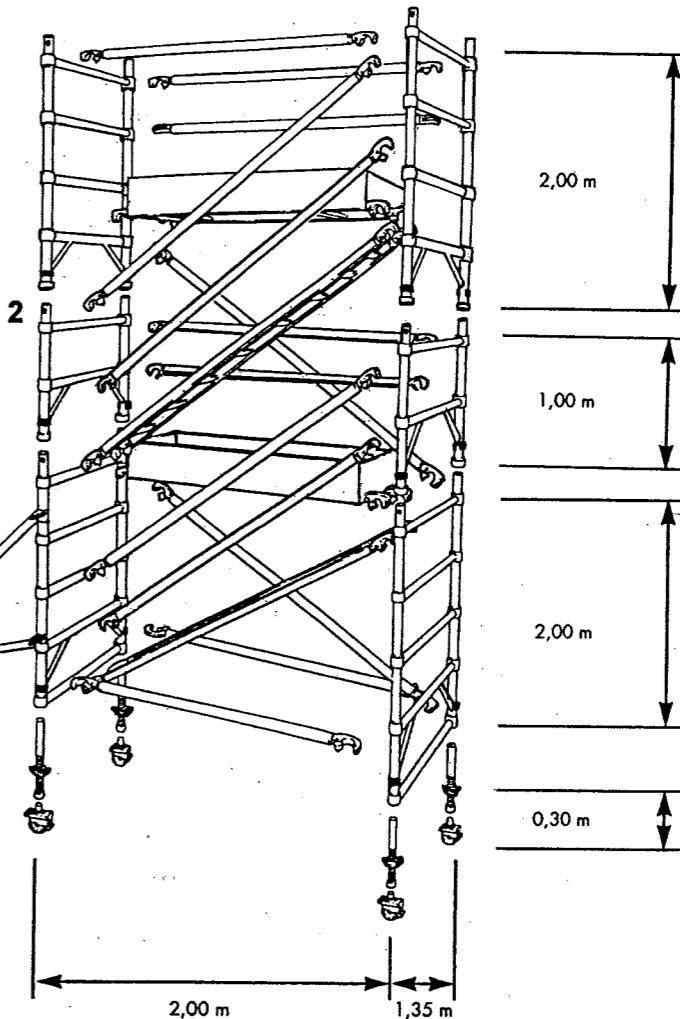

CONTRACT TOWERS SERIES 500

STAIRLADDER TOWERS - COMPONENT BREAKDOWN (1.35m X 2.0m)

PLATFORM HEIGHT/METRE	2.3	3.3	4.3	5.3	6.3	7.3	8.3	9.3	10.3	11.3	12.3
Castor	4	4	4	4	4	4	4	4	4	4	4
Adjustable leg - nut adjustment	4	4	4	4	4	4	4	4	4	4	4
2.0m 5 rung base frame	2	2	2	2	2	2	2	2	2	2	2
2m 4 rung frame	-	-	2	2	4	4	6	6	8	8	10
1m 2 rung frame	2	4	2	4	2	4	2	4	2	4	2
2m horizontal brace	5	5	7	7	9	9	11	11	13	13	15
Diagonal/banister brace	3	5	6	8	9	11	12	14	15	17	18
2m standard platform	1	1	2	2	3	3	4	4	5	5	6
Stairladder 8 tread	1	2	2	3	3	4	4	5	5	6	6
2m toeboard side	2	2	2	2	2	2	2	2	2	2	2
0.6m toeboard end	2	2	2	2	2	2	2	2	2	2	2
Stabiliser	-	4	4	4	4	4	4	4	4	4	4

FOR FULLY DECKED TOP PLATFORM:- Minus: 2 x diagonal/banister brace and 2 x 0.6m toeboard ends.
Plus: 1 x 2m full hatchdoor platform; 4 x 2m horizontal braces and 2 x 1.2m toeboard ends.

From * and above "tie-in" tower to a rigid structure. Whenever possible "tie-in" lower height towers, especially when used outdoors.

